

SERV-O-SPRAY OPERATING INSTRUCTIONS

For Single, Double, Triple and Quad Systems

SYSTEM INSTALLATION

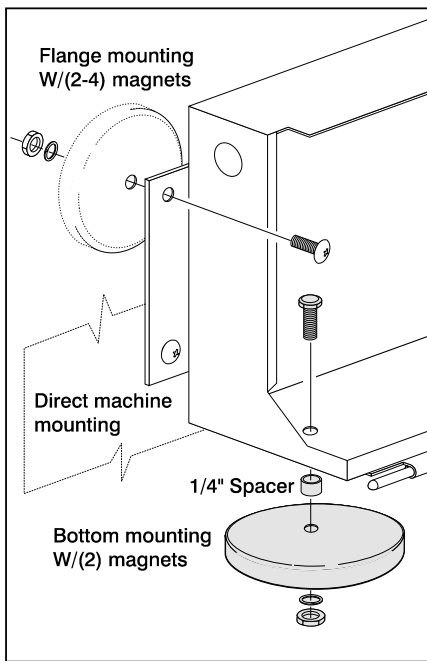

Figure 1. Mounting options

Step 1

Before mounting Serv-O-Spray to application equipment - Determine position and method of attachment - either directly or with optional magnets See *Figure 1*. Check for any obstructions that may pinch or kink liquid or air feed lines.

Mount Serv-O-Spray in close proximity to machine application by:

- a. *Mounting directly to machine.*
- b. *Mounting optional magnets to right and left flanges of Serv-O-spray case or bottom of case.*

Step 1.1

Mount and position nozzles as desired.

Step 2

Attach air supply line (Full line pressure) to 1/4" FPT inlet on air filter supplied with steel enclosure See *Figure 2*. For non-enclosed units - attach directly to top manifold block See *Figure 2-1*.

Step 3 (optional)

Reservoir or remote tank Low Level Switch should be hardwired prior to step 4. See *Figure 13 - Page 4* for wiring diagram.

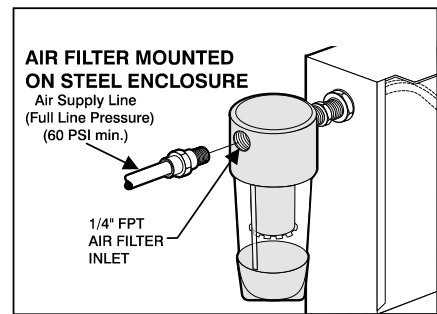

Figure 2. Air supply to filter

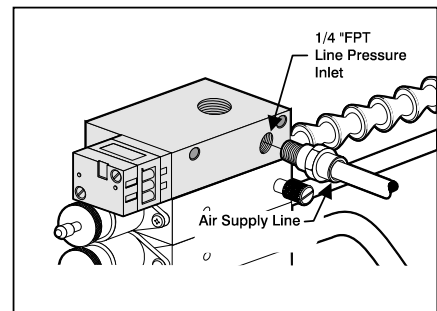
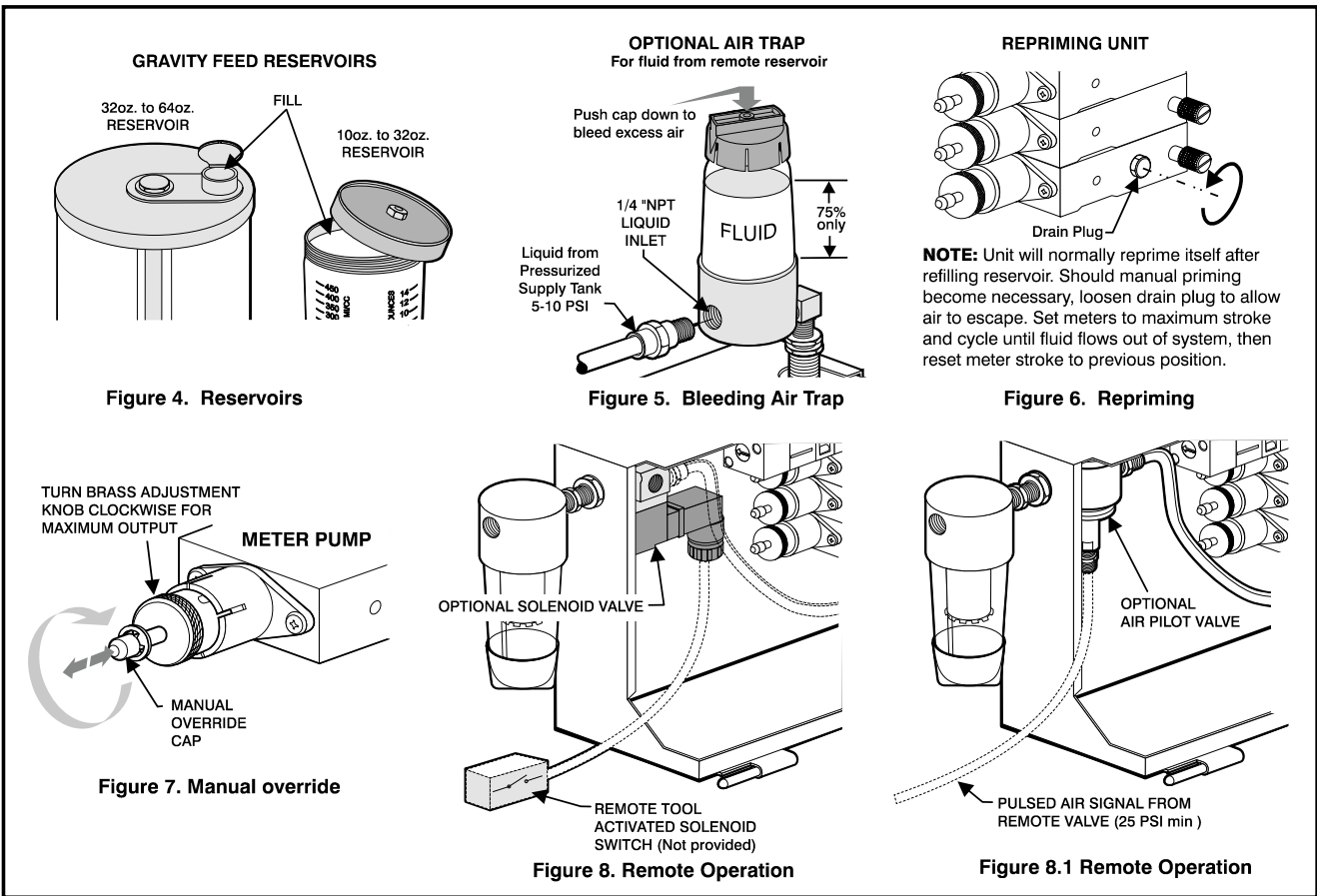

Figure 2-1. Air supply to manifold



Step 3.1

Wire solenoid valve See Figure 14 or connect air pilot valve See Figure 8.1

Step 4

Fill gravity feed reservoir See Figure 4 or (Air Trap if so equipped See Figure 5) Loosen Drain Plug See Figure 6 until liquid flows free of air. Tighten Drain Plug and cycle unit.

On units supplied with fluid from pressurized supply tank - Set supply tank pressure at 5-10 PSI. Depress air vent cap until trap is 75% full. See Figure 5

Step 5

Turn brass adjustment knob to maximum output setting and begin operating unit by turning air supply on and off, or by manually depressing override cap.

See Figure 7

Or start machine tool with remote switch installed to energize optional electric solenoid on unit. See Figure 8

Step 6

Close air metering screw when fluid is seen coming out of nozzle supply tube with each cycle, open the air metering screw to the desired degree of atomization. See Figure 10 **NOTE:** Use minimum amount of air atomization to spread lubricant and deliver it to application area.

LIQUID OUTPUT ADJUSTMENT

Begin Operation and adjustment by: Rotating brass adjustment knobs on meters for correct liquid output. See Figure 9 **NOTE:** Meters are factory preset for maximum fluid delivery.

RED PLASTIC TIP

- 1 Drop Meter Output (cc/stroke)
- 0.0cc. - 0.0015cc. Low Range
- 0.002cc. - 0.0035cc High Range

For low range adjustment, E-Clip must be in groove that produces shortest stroke.

See Figure 11

To decrease fluid flow, turn knob counterclockwise.

To completely shut off meter, rotate knob counterclockwise until knob is against E-clip. See Figure 9

BLACK PLASTIC TIP

- 3 Drop Meter Output (cc/stroke)
- 0.0cc. - 0.0035cc. Low Range
- 0.002cc. - 0.100cc High Range

For maximum range adjustment, E-Clip must be in groove that produces longest stroke. See Figure 12

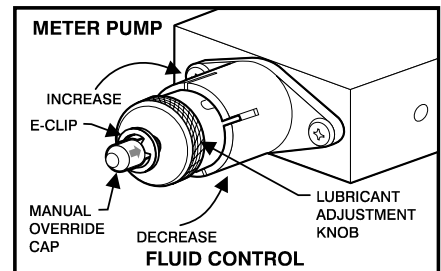

Figure 9. Fluid Adjustments

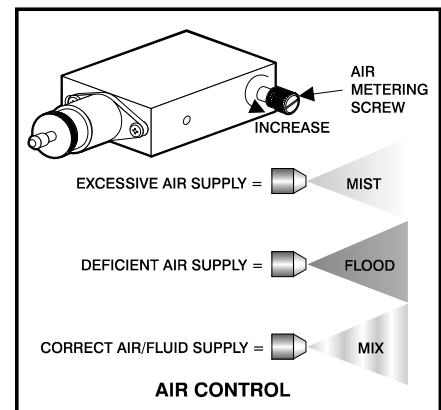

Figure 10. Air Control

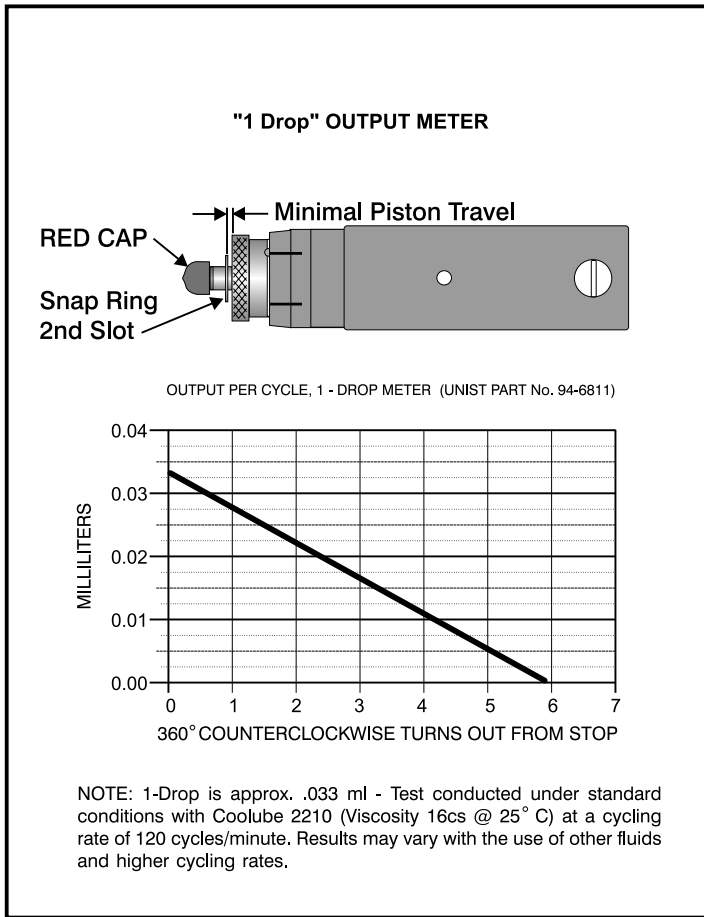

Figure 12. 1-Drop Output Meter

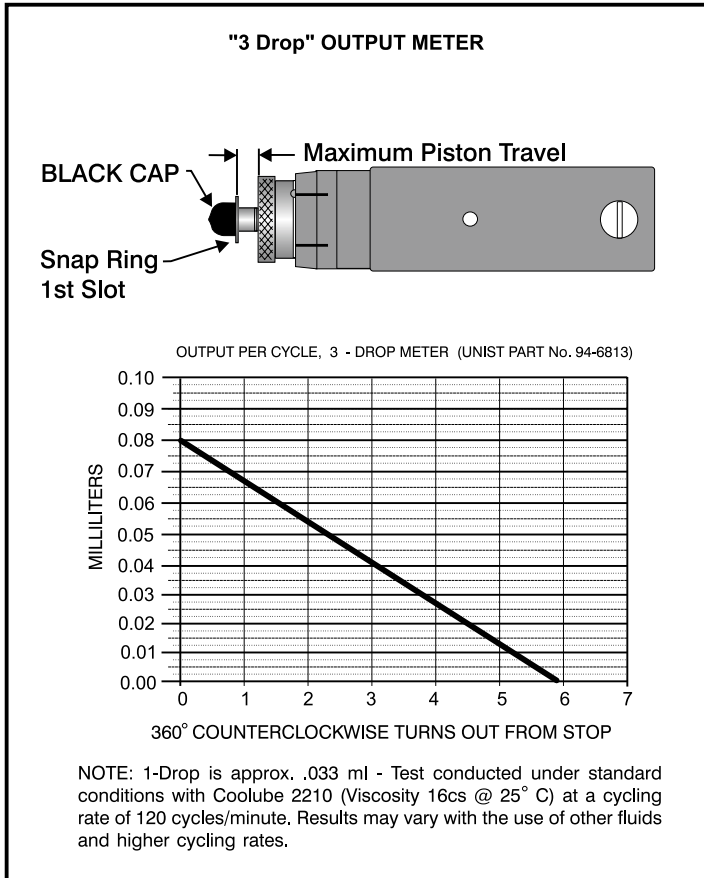

Figure 13. 3-Drop Output Meter

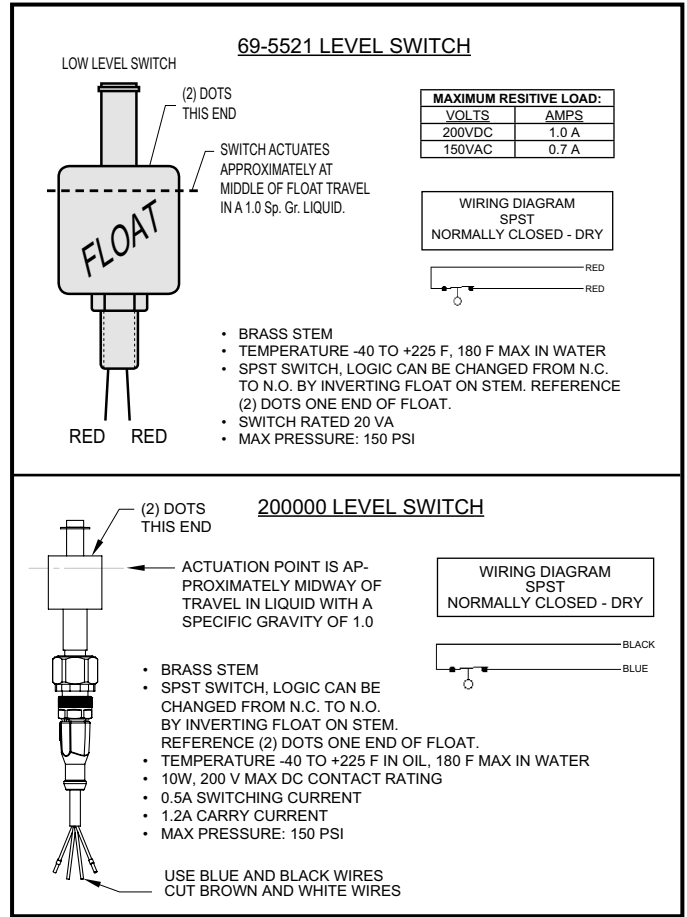

Figure 14. LOW LEVEL SWITCH

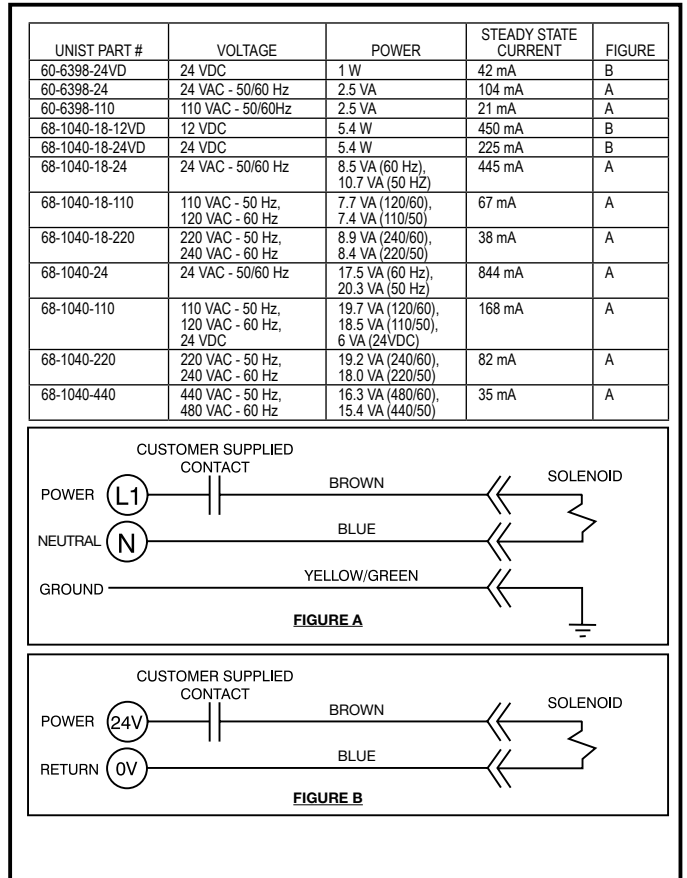
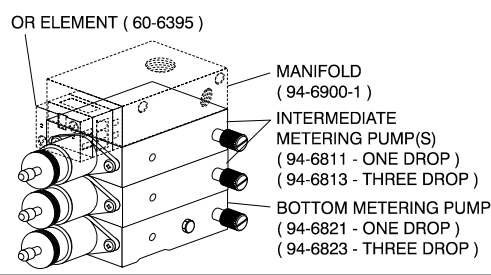

Figure 15. SOLENOID VALVES

STANDARD COMPONENTS



OR ELEMENT (60-6395)

MANIFOLD (94-6900-1)

INTERMEDIATE METERING PUMP(S) (94-6811 - ONE DROP) (94-6813 - THREE DROP)

BOTTOM METERING PUMP (94-6821 - ONE DROP) (94-6823 - THREE DROP)

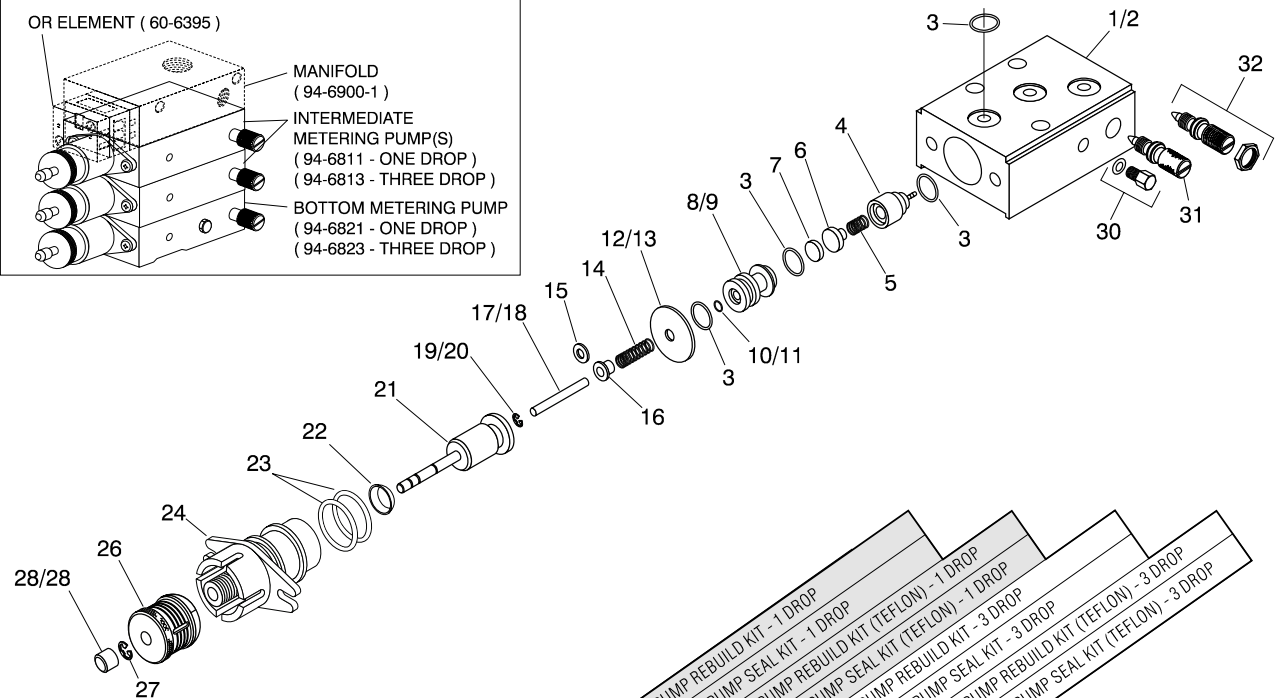

EXPLODED VIEW OF INTERNAL KIT PARTS
- ORDER BY KIT NUMBER ONLY -

ITEM	PART NUMBER	DESCRIPTION	QTY.	QTY.	QTY.	QTY.	QTY.	QTY.	QTY.	QTY.	QTY.
1	94-6900-2	METER BODY (INTERMEDIATE)	-	-	-	-	-	-	-	-	-
2	94-6900-3	METER BODY (BOTTOM)	-	-	-	-	-	-	-	-	-
3	2-012-V884-75	O-RING	3	3	-	-	3	3	-	-	-
4	89-6900-10A	CHECK HOUSING	-	-	-	-	-	-	-	-	-
5	9303-108	CHECK SPRING	1	-	1	-	1	-	1	-	-
6	9303-107	CHECK BODY	1	-	1	-	1	-	1	-	-
7	9303-106	CHECK SEAL	1	1	-	-	1	1	-	-	-
8	94-6808-12	INSERT	1	-	1	-	-	-	-	-	-
9	94-6808-18	INSERT	-	-	-	-	1	-	1	-	-
10	2-006-V884-75	O-RING	1	1	-	-	-	-	-	-	-
11	2-008-V884-75	O-RING	-	-	-	-	1	1	-	-	-
12	9303-110	WASHER	1	-	1	-	-	-	-	-	-
13	95-1001	WASHER	-	-	-	-	1	-	1	-	-
14	94-6100-8	RETURN SPRING	1	-	1	-	1	-	1	-	-
15	94-6803-1	WASHER	1	-	1	-	-	-	-	-	-
16	94-6800-2	WASHER	-	-	-	-	1	-	1	-	-
17	94-6806-12	LIQUID PIN	1	-	1	-	-	-	-	-	-
18	94-6806-18	LIQUID PIN	-	-	-	-	1	-	1	-	-
19	5103-0012SPPR	RETAINING CLIP	1	-	1	-	-	-	-	-	-
20	5103-0018SPPR	RETAINING CLIP	-	-	-	-	1	-	1	-	-
21	94-6805A	PUSH ROD ASSY.	1	-	1	-	1	-	1	-	-
22	9303-111	U-CUP	1	1	-	-	1	1	-	-	-
23	2-018	O-RING	2	2	-	-	2	2	-	-	-
24	94-6801	END CAP	1	-	1	-	1	-	1	-	-
25	832-3/8PHPHMS	SCREW	-	-	-	-	-	-	-	-	-
26	94-6807	ADJUSTMENT KNOB	1	-	1	-	1	-	1	-	-
27	E-21	RETAINING CLIP	1	-	1	-	1	-	1	-	-
28	701-1R	STOCK CAP, RED	1	-	1	-	-	-	-	-	-
29	701-89	STOCK CAP, BLACK	-	-	-	-	-	-	-	-	-
30	6134	DRAIN PLUG W/GASKET	-	-	-	-	-	-	-	-	-
31	94-6202	METERING SCREW	-	-	-	-	-	-	-	-	-
32	94-6202-J	JAM NUT METER SCREW	-	-	-	-	-	-	-	-	-

Uni-MAX SERV-O-SPRAY COMPONENTS AND OPTIONS

69-461 and 69-461-PC-LL (W/LOW LEVEL)

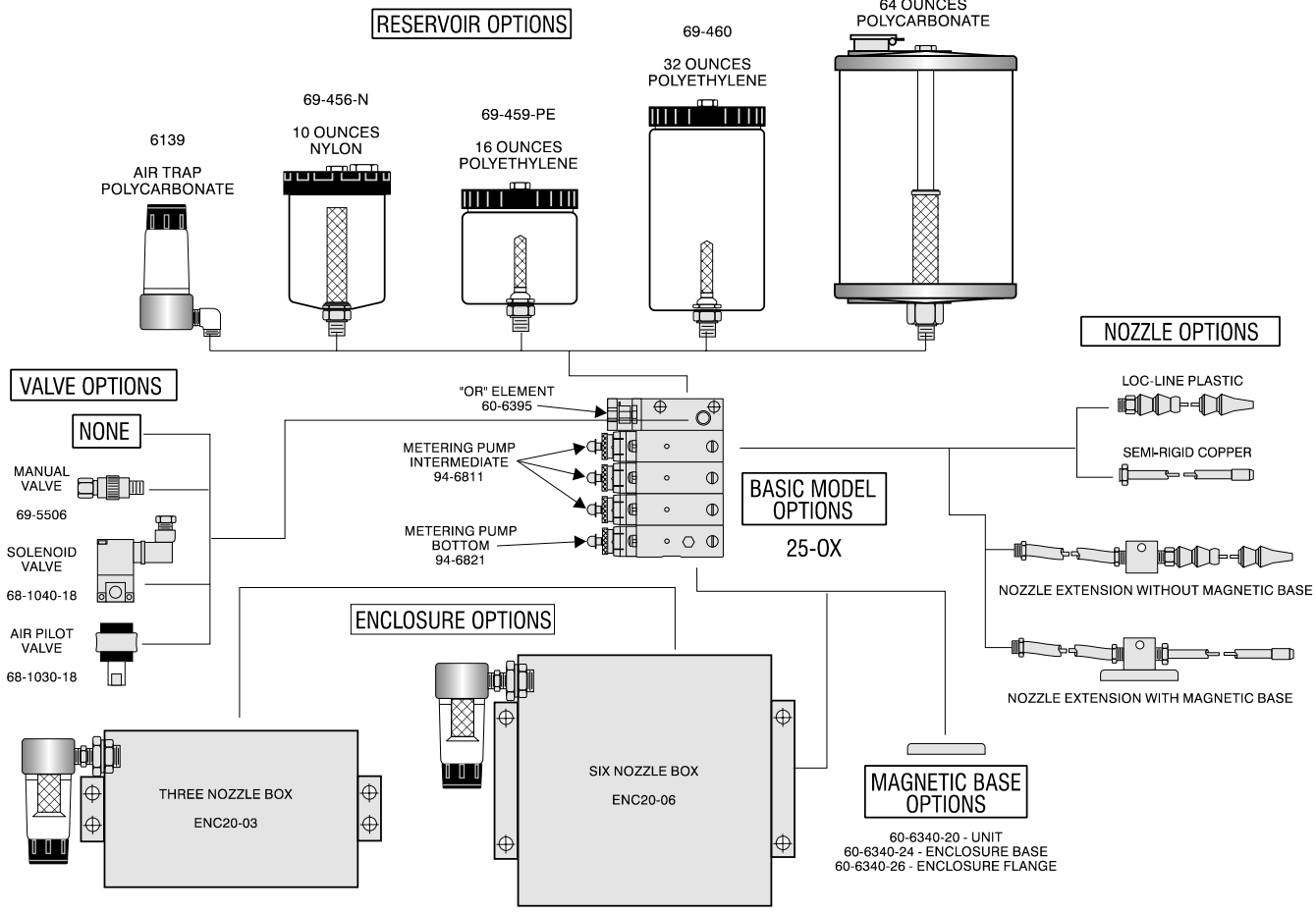

Uni-MAX SERV-O-SPRAY NOZZLE EXTENSIONS

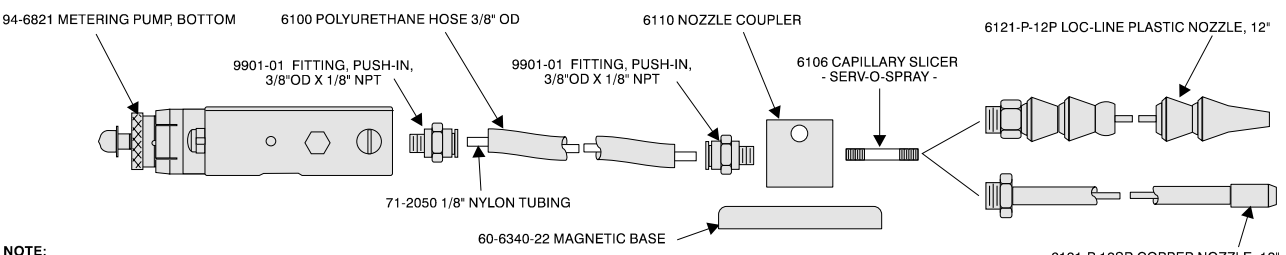
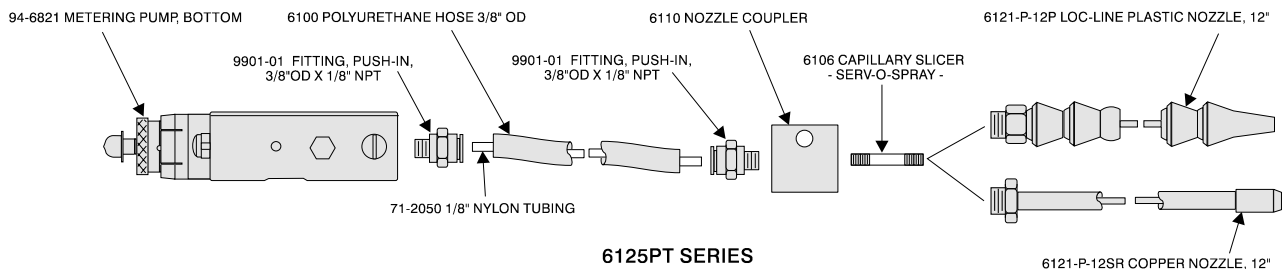

NOTE:
METERING PUMPS ARE SHOWN TO ILLUSTRATE TYPICAL CONFIGURATIONS AND ORIENTATION OF PARTS.
METERING PUMP IS NOT TO BE CONSIDERED PART OF HOSE ASSEMBLY.

TROUBLE SHOOTING OF UNI-MAX SPRAY SYSTEMS

PROBLEM	REMEDY
<p>No fluid output (Manual output moves freely) often following reservoir evacuation.</p>	<ol style="list-style-type: none"> 1. Check reservoir level. 2. Check for stroking of meter (set to max)- use full air line inlet pressure. 3. Check for fluid movement in capillary tubing at each meter stroke. 4. Loosen 5/16" brass hex bleed screw 2 revolutions until only fluid comes out -close screw tightly. -recheck meter output by manually or automatically cycling.
<p>Reduced fluid output</p>	<ol style="list-style-type: none"> 1. Check air inlet pressure (maximum available) so that meters operate "crispily". 2. Non-Lubricating fluids such as water and solvents could cause premature wear of internal parts. Consult factory for rebuild kit.
<p>Pulse Generator not functioning (Coolubricator only)</p>	<ol style="list-style-type: none"> 1. Remove pulse generator and check air inlet screen for particulate matter. 2. If none found, replace pulse generator.
<p>Slow (sluggish) meter operation</p>	<p>Be sure air inlet pressure is maximum available. A slow or incomplete return could be caused by a broken spring on inadequate lubrication of U-Cup . Rebuild meter.</p>
<p>Meter depressed and not returning.</p>	<p>A piece of debris in the fluid could cause the liquid pin to "jam". Disassemble and reassemble, checking for foreign particles.If a return spring is broken, rebuild meter.</p>
<p>Fluid flowing continuously out of the nozzle or reservoir emptying without system running.</p>	<p>The check valve seal is not properly functioning. Check the seat for cleanliness (or turn it over). Also, examine the check seal spring.</p>
<p>Fluid accumulation in outer tubing.</p>	<p>This can result in Coolubricator systems due to insufficient atomizing air exiting the nozzle.</p> <ol style="list-style-type: none"> 1. Increase atomizing air flow or 2. Direct nozzle coupler outlet downward to encourage excess fluid to exit nozzle.
<p>Air bubbling upward into fluid reservoir.</p>	<p>Check the valve seat (check seal) for possible leakage (turn over seat). A static sealing o-ring may need replacement. Use a rebuild kit.</p>

